

ANEXO B

SISTEMA CONSTRUCTIVO CONCORDIA

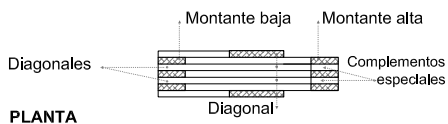

PIE DE PORTICO

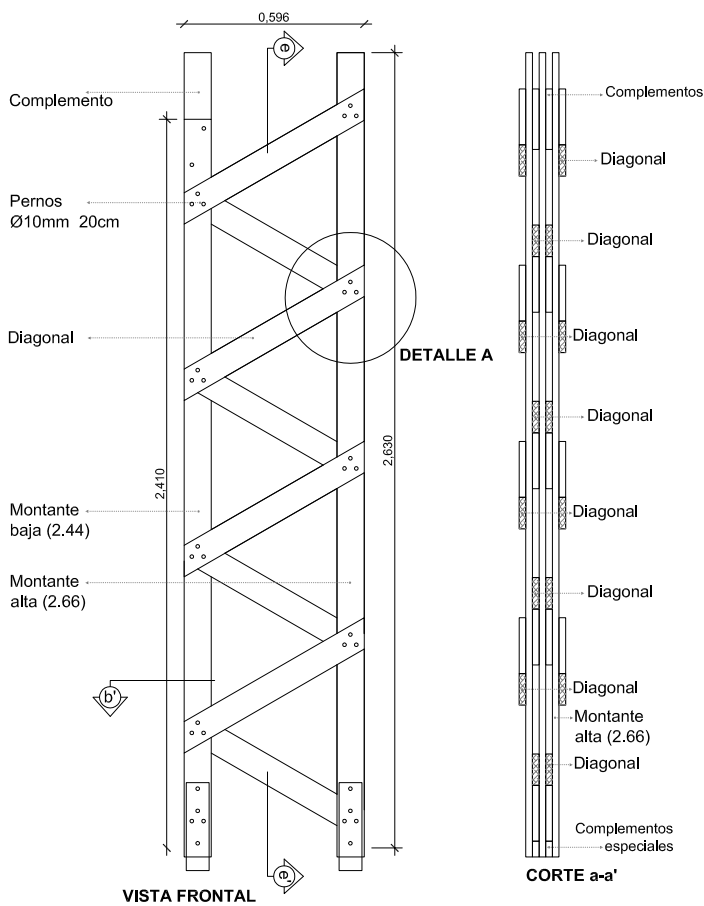
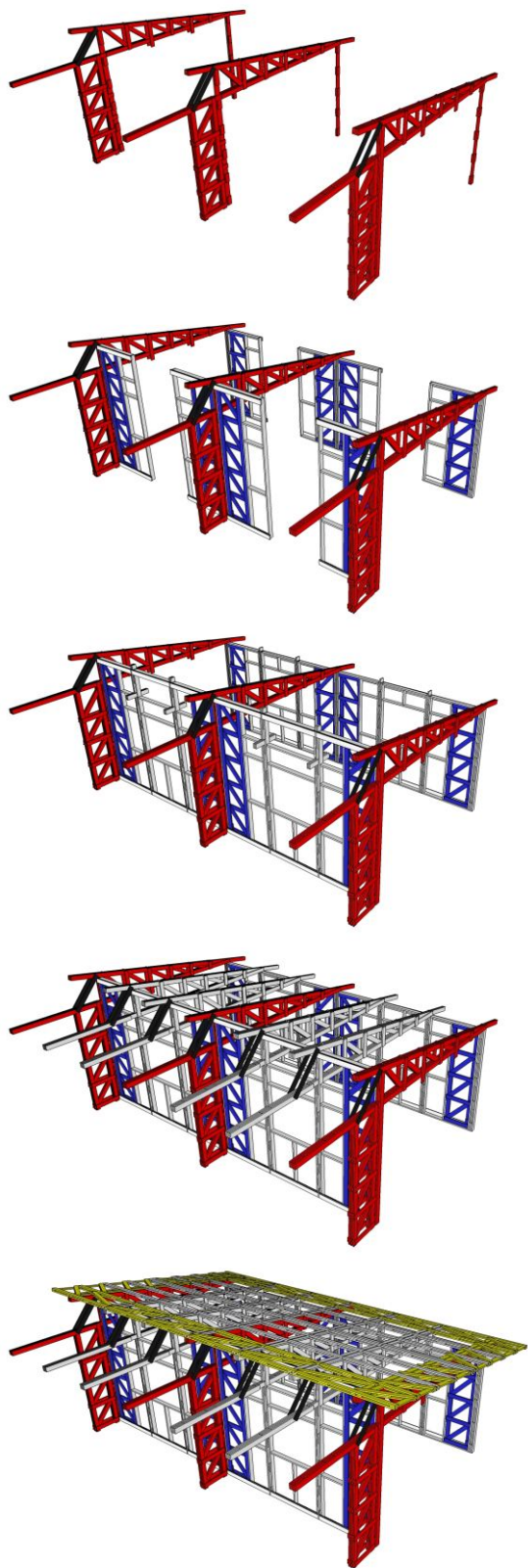



PANEL ALTO ESTRUCTURAL VENTANA 3.12m

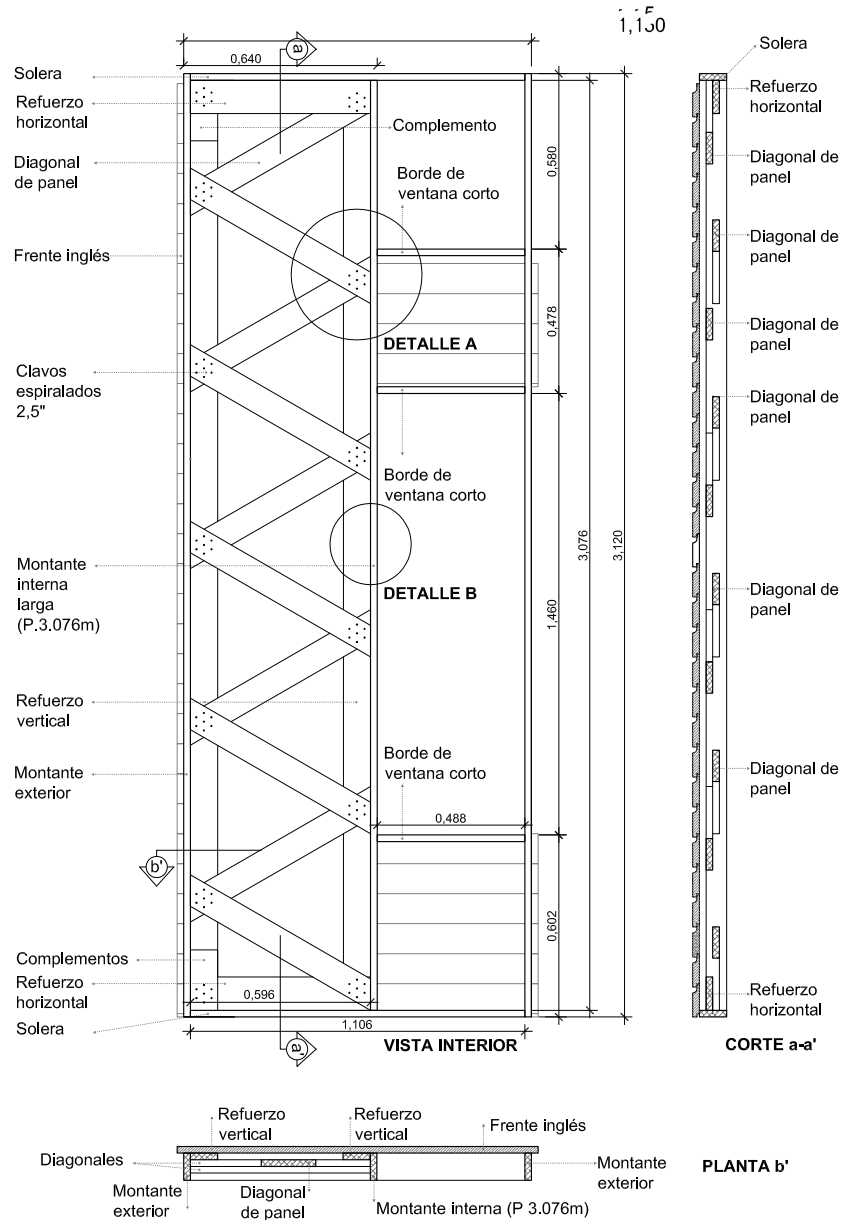

PLANTILLA TIPO A PARA INDICAR POSICIÓN DE PERNOS

DETALLE A
vista interior

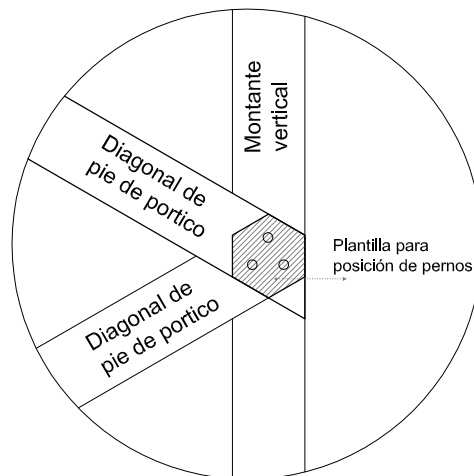

DETALLE B
en planta

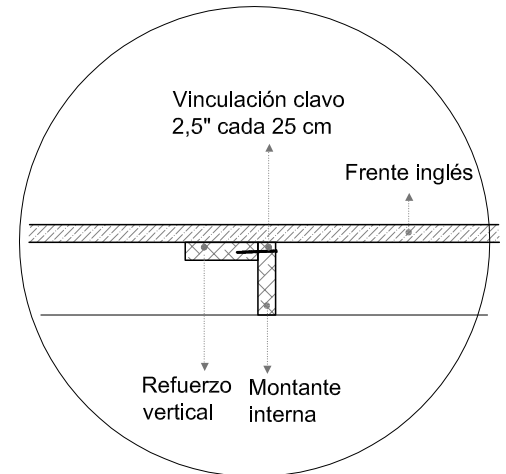



PANEL BAJO NO ESTRUCTURAL VENTANA 2.54m

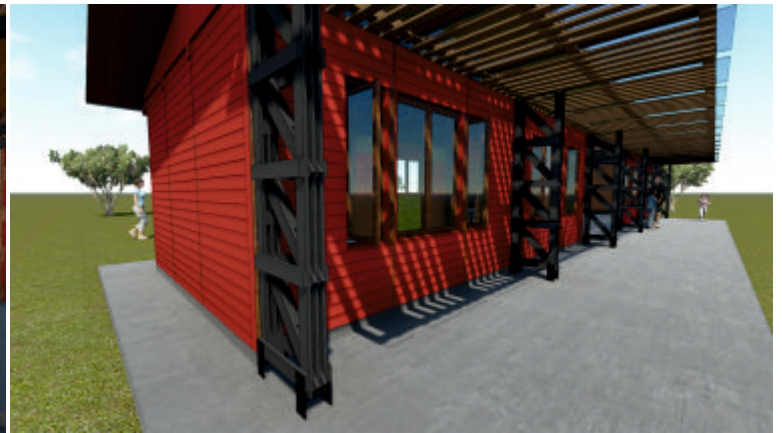
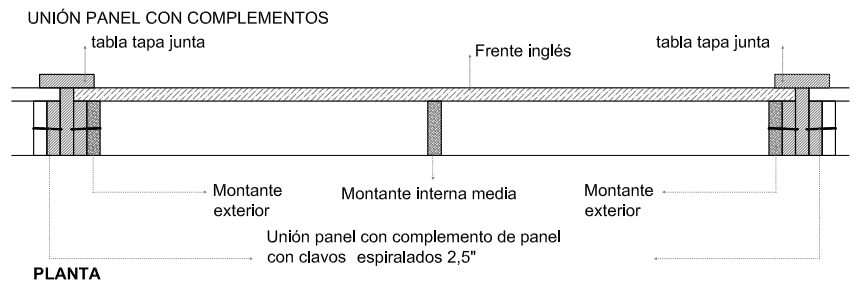
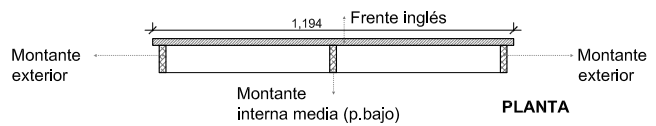
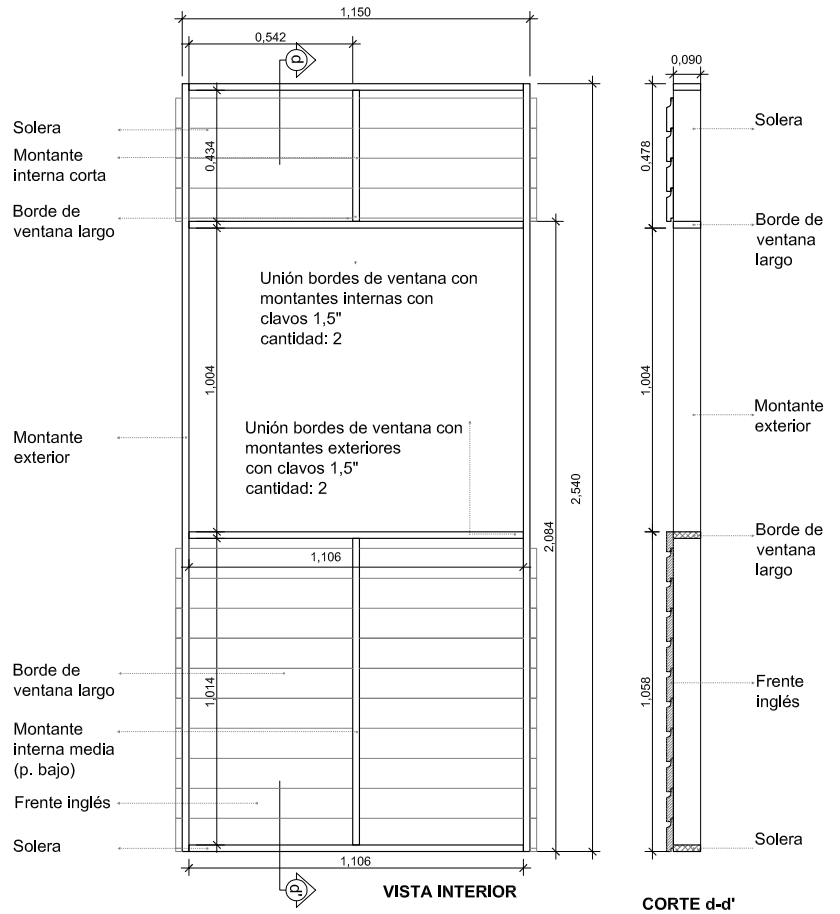

CABRIADA

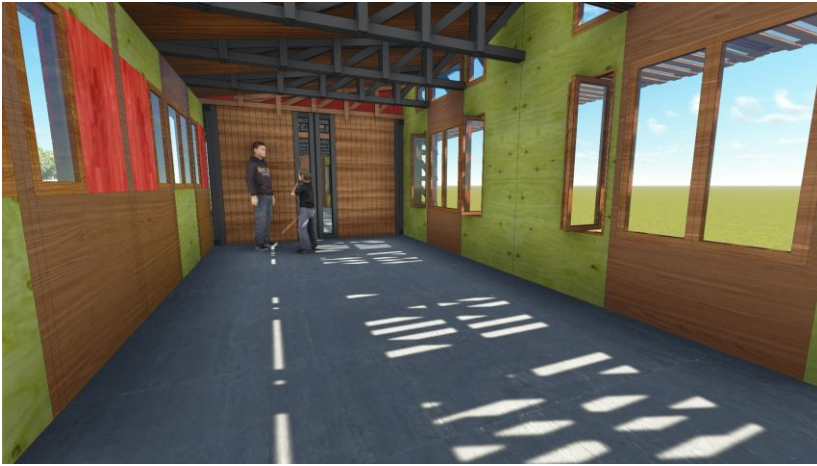
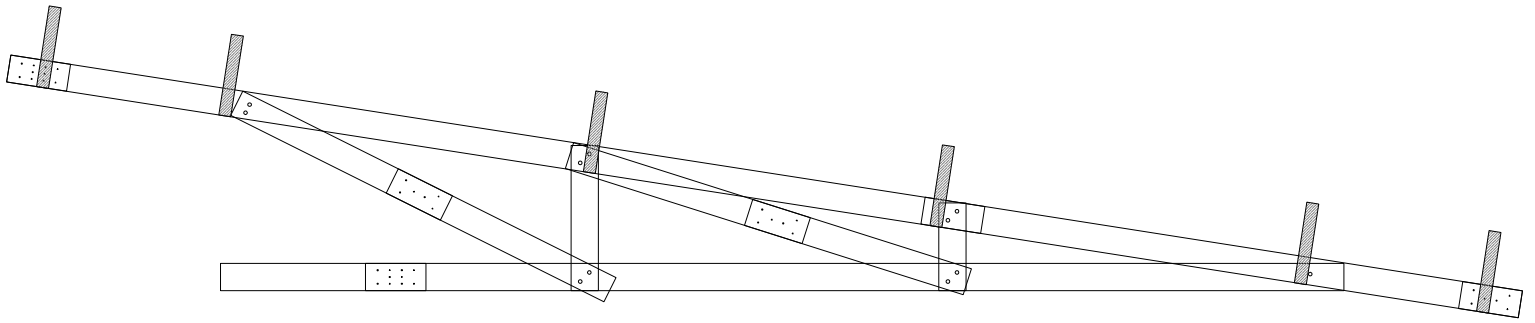

PANELES DE TECHO DE VOLADIZO

Montante Diagonal Montante inferior Diagonal superior Solera superior Montante

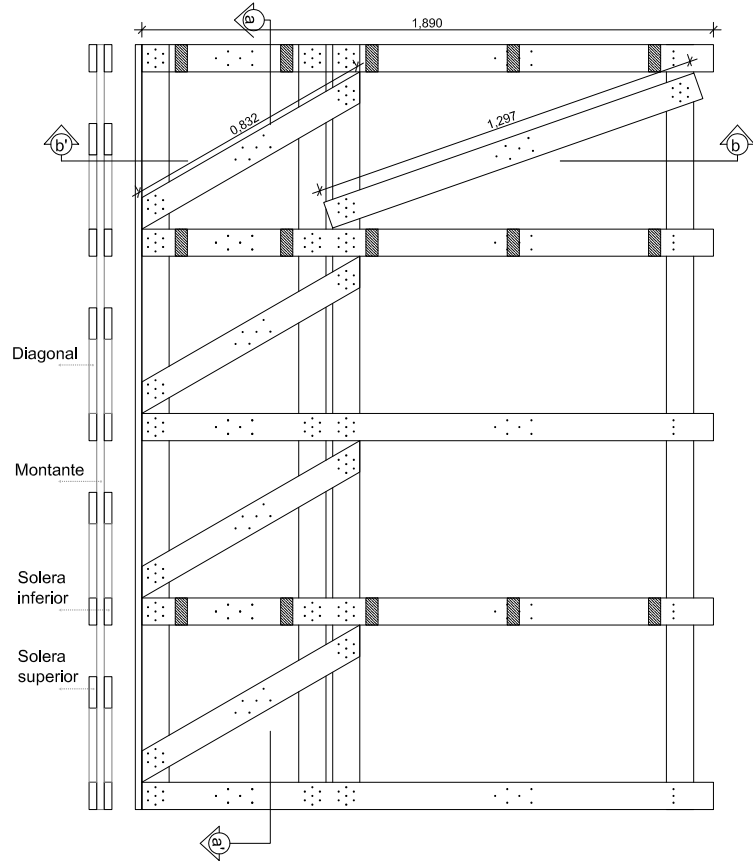
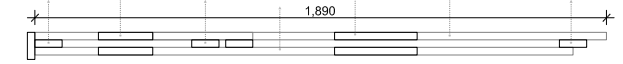

Red interactoral – Proyecto CONCORDIA

(27 de julio 2011)

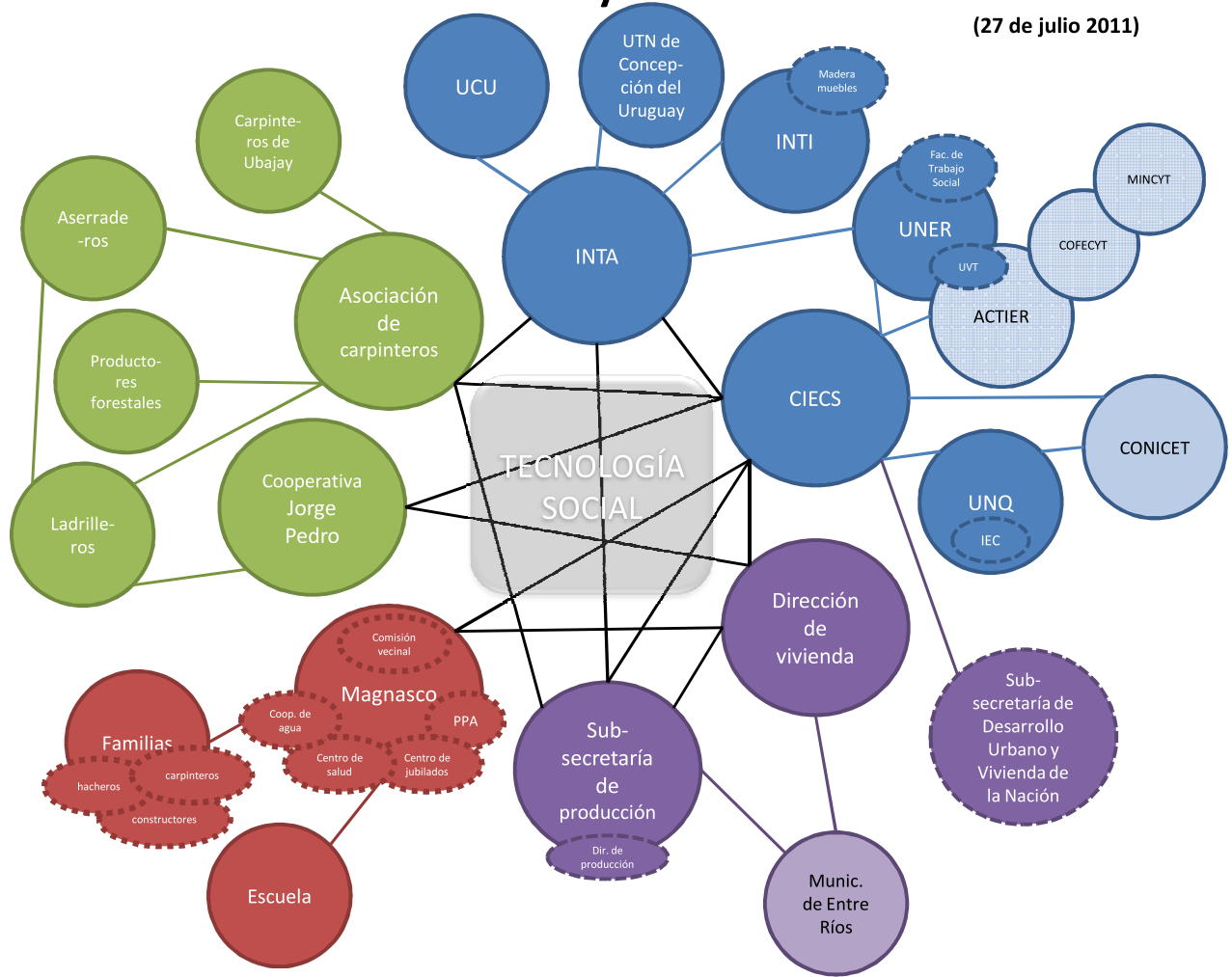

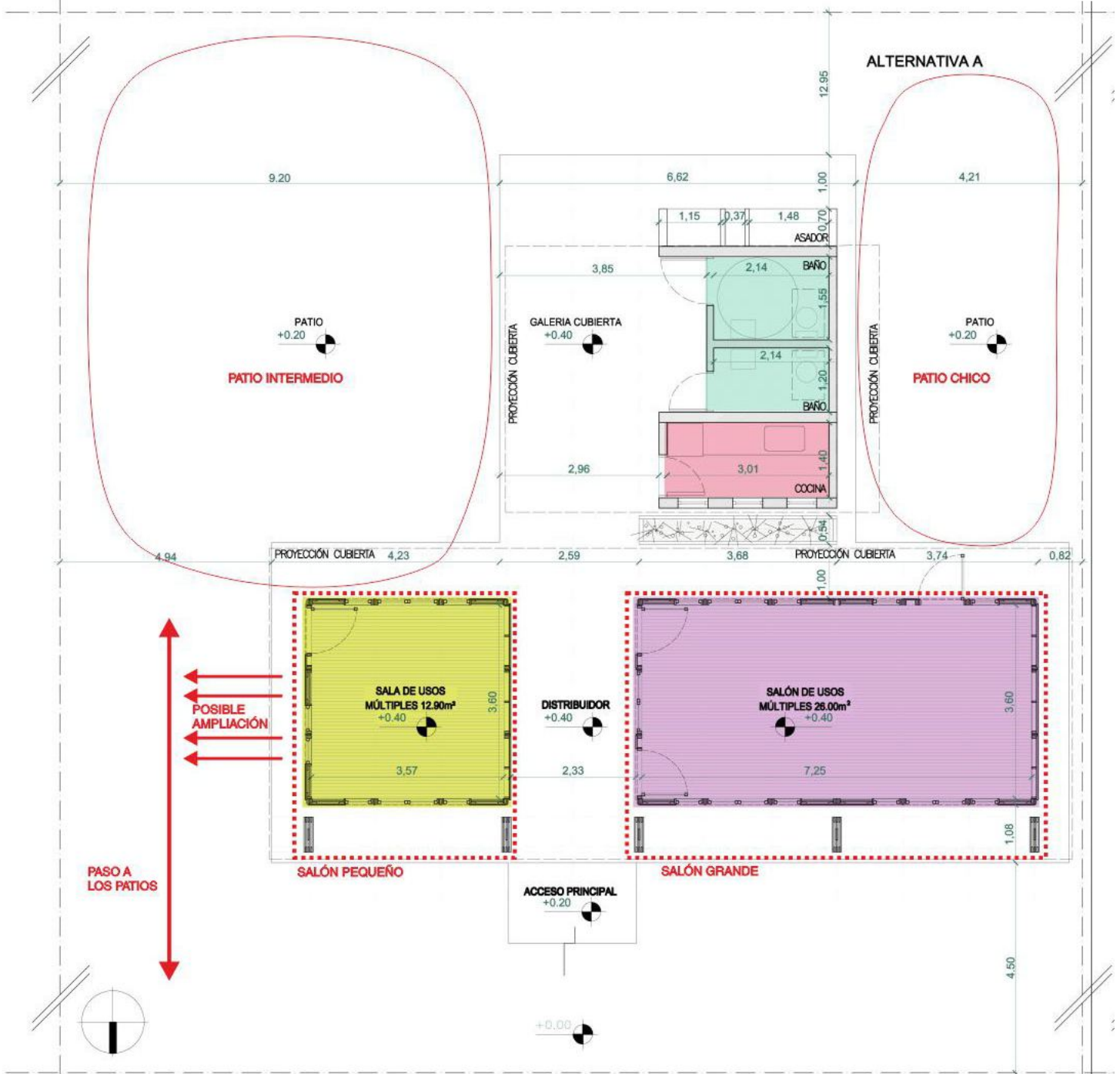

NOTA: ESTA OPCIÓN TIENE UNA SALA MÁS PEQUEÑA, QUE TIENE LA POSIBILIDAD DE AMPLIARSE A FUTURO, AUNQUE MIENTRAS CONSERVA LAS DIMENSIONES ACTUALES LIBERA UNA CIRCULACIÓN DIRECTA A LOS PATIOS DESDE EL LATERAL DEL EDIFICIO. EL OTRO SALÓN ES DE MAYORES DIMENSIONES. LA DISPOSICIÓN DE LOS SANITARIOS FRACCIONA LOS PATIOS EN DOS, LO QUE PERMITE DOS USOS EN SIMULTÁNEO. LOS BAÑOS ABREN DIRECTAMENTE A LA GALERÍA SEMICUBIERTA, Y LA COCINA SE ENCUENTRA EN EL OTRO EXTREMO DEL ASADOR. POR ÚLTIMO EL DISTRIBUIDOR OCUPA SOLO DOS MÓDULOS.

